

Volume IV, Issue 4

April 2024



American Journal of
Electronics & Communication

Society for Makers, Artists, Researchers and Technologists,
USA 6408 Elizabeth Avenue SE, Auburn, Washington 98092.

ISSN 2690-2087

Content

Sl. No.	Title of the Paper	Authors Name	Page
1	Development Of Assistive Humanoid Robot	Soumayadeep Pal , Avrajeet Ghosh, Rupsa Bhattacharya , Atreyee Saha , Ankit Kar, Susmita Das	1-8
2	Development Of Iot Based Monitoring System In Smart Agriculture	Jinnat Saba , Shams Tanveer , Soumyata Singh, Sanghamitra Layek , Bikas Mondal	9-16
3	Smart Helmet For Alcohol Detection	Apurba Basumallick , Akash Bhattacharyya , Somshubhra Bose , Anirban Saha, Sanghamitra Layek	17-22
4	Design Approach Of A Gesture And Emg(Electromyography) Controlled Bionic Arm	Sparsho Chakraborty, Sayantan Maitra, Md. Avaish Siddiqui, Diksha Jha, Susmita Das	23-27
5	Li-Fi Music Systems For Concerts	Aishani Sil , Souradeep Das , Arpita Das , Rimi Sengupta	28-32



DEVELOPMENT OF ASSISTIVE HUMANOID ROBOT

Soumayadeep Pal¹, Avrajeet Ghosh¹

¹B. Tech Student, Department of Electronics and Instrumentation Engineering

Rupsa Bhattacharya², Atreyee Saha², Ankit Kar²

²B. Tech Student, Department of Electronics and Computer science

Susmita Das³

³Assistant Professor, Department of Electronics and Instrumentation Engineering 81,

Nilgunj Road, Jagrata Pally, Deshopriyo Nagar, Agarparā, Kolkata, West Bengal

700109

*{*Email – susmitad2k17@gmail.com}*

Abstract – A dream of humanoid robot researchers is to develop a complete “human-like” (whatever that means) artificial agent both in terms of body and brain. It represents a significant breakthrough in the field of robotics, aiming to mimic and replicate human-like characteristics and functionalities. On the other hand, brain research has begun to produce computational models such as LIDA. In this paper, we propose an intermediate approach for body-brain integration in a form of a scenario-based distributed system. Busy hospital Emergency Departments (ED) are concerned with shortening the waiting times of patients, with relieving overburdened triage team physicians, nurses and medics, and with reducing the number of mistakes. It enhances the learning experience through

interactive tutoring and educational support. Humanoid robotics can collaborate with human workers in industrial settings and serve as receptionists, guides and assistants in public spaces. Advances in humanoid robotic design, in sensor technology, and in cognitive control architectures make such a system feasible, at least in principle. As technology advances, these robots are poised to play an increasingly prominent role in various aspects of our lives, from healthcare and education to entertainment and industry. However, addressing challenges related to cost, safety, and ethics will be essential to unlocking their full potential.

Keywords – humanoid, human-like, technology, healthcare, industrial.

1.0 INTRODUCTION

Ever since the dawn of civilization, we as humans have been fascinated with machines and devices that can replicate aspects of biology, in particular of ourselves. Some are created for our entertainment, some to facilitate us in our daily lives, and historically speaking some were even created for imitating the power of gods (religious relics). The themes of these developments have gone in and out of trends in various forms, but the most fundamental issues were to explore points toward the eventuation of robotics as we know it today.

Humanoid may be defined as something that resembles or looks like a human being and has certain human characteristics like it has a similar shape as that of a human body. In general, a humanoid robot has a torso, a head, two arms, and two legs, and are categorized as male humanoids and female humanoids [1]. These robots are designed to simulate human-like appearance, movement, and behaviour, and they represent a fusion of mechanical engineering, artificial intelligence, and cognitive science. But in some applications, partial body parts are designed to perform specific work or research, such as only the lower part of the body to perform research operations on the gait of the robot [2]. These have the complex structure and design when compared with other robots, so more and more attention is drawn in this area to improve the design and control parameters of humanoids [3-5]. The humanoid robot can mimic the human expressions with eyes and mouth either by using mechanisms or display screen to express the gestures [6]. Apart from the research in this field, humanoids are being developed to use as an assistant robot and also to perform dirty and dangerous tasks. Applications of humanoid robots are well established in the field of Health care Defence, Education, and Entertainment.

2.0 OBJECTIVES

The objective of a humanoid robot is to develop a machine that can mimic or replicate human-like physical characteristics and behaviour and coexist and collaborate with humans in a manner that is safe, efficient, and beneficial to society.

Here are some common objectives associated with humanoid robots:

Human-Like Appearance: One of the primary objectives of humanoid robots is to mimic the human form. They are designed to have a head, torso, arms, and legs, resembling the physical structure of a human being. This allows them to interact with humans in a more natural and intuitive manner.

Humanoid Interaction: Humanoid robots aim to facilitate seamless interaction with humans. They are equipped with sensors and actuators that enable them to perceive and interpret human gestures, speech, and expressions. By understanding and responding to human cues, they can engage in effective communication and collaboration.

Task Automation: Humanoid robots can be programmed to perform a wide range of tasks, both complex and repetitive. They can be used in industries such as manufacturing, healthcare, and logistics, where they can take over tasks that are dangerous, physically demanding, or require high precision. By automating repetitive or physically demanding tasks, they enhance productivity and improve quality of life.

Research and Development Platform: Humanoid robots serve as valuable research platforms for studying human locomotion, cognition, and interaction. By mimicking human capabilities, they allow scientists and engineers to explore and understand human

behaviours in a controlled environment. This knowledge can further drive advancements in robotics and artificial intelligence.

Personal Assistance: Humanoid robots can assist individuals with disabilities or elderly people in their daily activities. They can help with tasks like fetching objects, providing reminders, monitoring vital signs, or offering companionship and emotional support.

Industrial and Manufacturing Assistance: In industrial settings, humanoid robots may assist in tasks that require precision and dexterity, such as assembly, quality control, and material handling.

Education and Entertainment: Humanoid robots can be used in educational settings to engage students in STEM (science, technology, engineering, mathematics) subjects or provide personalized tutoring. They can also be employed in entertainment industries, such as theme parks or museums, to entertain and engage visitors.

Versatile Mobility: Humanoid robots are designed to move and navigate in environments designed for humans. They possess the capability to walk, run, climb stairs, and even perform complex movements. This mobility allows them to operate in various settings, such as homes, offices, hospitals, and disaster stricken areas.

Social and Emotional Interaction: Humanoid robots aim to establish emotional connections

3.0 METHODOLOGY

with humans. Through advanced algorithms and artificial intelligence, they can recognize and respond to emotions, engage in empathetic conversations, and provide companionship. This aspect of human-robot interaction holds promise for applications in healthcare, therapy, and education.

Technological Advancement: The development of humanoid robots pushes the boundaries of robotics and AI technologies. By addressing challenges related to balance, dexterity, and perception, researchers strive to enhance the capabilities of humanoid robots. This leads to breakthroughs in robotics, such as improved sensor technologies, advanced control algorithms, and more robust machine learning techniques.

Safety: Ensuring the safety of both the robot and humans is a primary objective. Humanoid robots must be equipped with mechanisms and sensors to avoid collisions, mitigate potential hazards, and protect users from harm. Besides that, it has been proposed for use in exploration missions to other planets or disaster response scenarios, where they can navigate complex environments and perform tasks that are challenging for human.

Overall, the objective of humanoid robots is to create versatile and interactive machines that resemble and interact with humans, aiming to assist in various tasks, foster social connections, and advance the field of robotics and artificial intelligence.

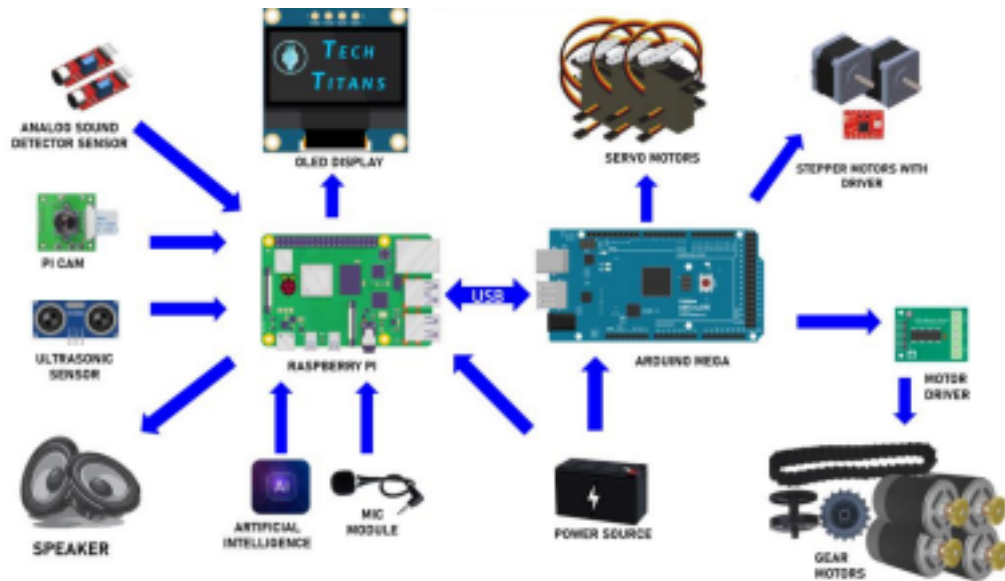

Fig.1: Schematic Diagram

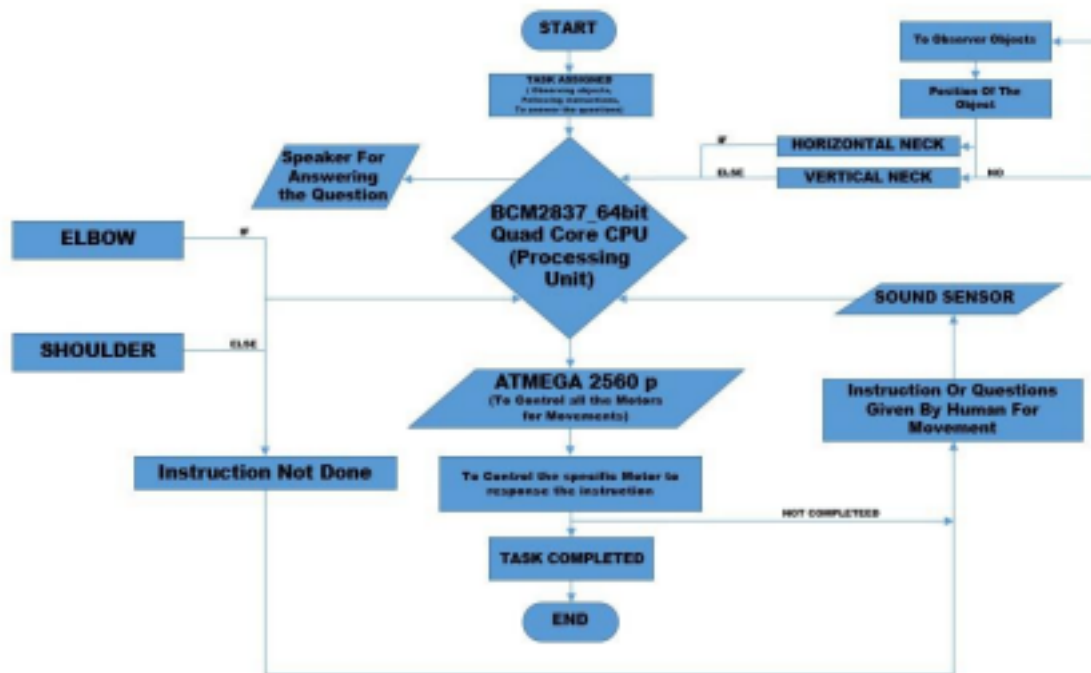

Fig.2: Flowchart of the work

Our total system is dividing in two parts. At first there is a microprocessor which is controlled the microcontroller. A mic and a speaker are connected with the microprocessor which is used to answer the basic question.

In the second, using the mic all the instructions process in the microprocessor and control the microcontroller to move the body parts according to the instructions. All the motors

are connected with the microcontroller and according to the used instructions the motors rotate to change the location of the system and to carry any heavy loaded things.

The development and methodology behind humanoid robots involve a combination of engineering, robotics, and artificial intelligence (AI) techniques. Here's an overview of the typical methodology used

in creating humanoid robots:

Purpose: Determine the specific tasks and functions the humanoid robot should be capable of performing. This could range from simple actions like walking and grasping objects to more complex tasks such as interacting with humans or performing specific jobs.

Design and Mechanical Engineering: Design the physical structure of the humanoid robot, considering factors like size, weight, range of motion, stability, and durability. Mechanical engineering principles are applied to create joints, limbs, and overall body structure that mimic human capabilities.

Sensing and Perception: Incorporate sensors and perception systems into the robot to enable it to perceive and understand its environment. Common sensors include cameras, depth sensors, touch sensors, and force/torque sensors. These sensors provide data that helps the robot understand the surrounding world and react accordingly.

Actuation and Motion Control: Implement actuators and motion control systems to enable the robot's movements. Electric motors, hydraulic systems, or pneumatic systems may be used to control the joints and limbs of the humanoid robot. Sophisticated algorithms are employed to ensure smooth and coordinated motion.

Artificial Intelligence and Control Systems: Develop AI algorithms and control systems to enable the robot to process sensor data, make decisions, and execute tasks. Machine learning techniques, such as reinforcement learning or

deep learning, can be used to train the robot's AI systems. These algorithms enable the robot to learn from its interactions with the environment and improve its performance over time.

Human-Robot Interaction: Design the interface and communication methods for the humanoid robot to interact with humans effectively. This may involve natural language processing, gesture recognition, facial expression analysis, or other means of communication.

Safety and Ethical Considerations: Ensure that the robot is designed with safety measures to prevent accidents or harm to humans. Implement fail-safe mechanisms, collision detection, and emergency shutdown procedures. Ethical considerations, such as privacy, consent, and accountability, should also be taken into account.

Testing and Iteration: Conduct rigorous testing to validate the robot's performance, reliability, and safety. Iteratively refine and improve the design based on testing results and user feedback.

Deployment and Real-World Application: Once the robot passes all necessary tests and meets the desired requirements, it can be deployed for real-world applications. This could include use in industries, healthcare, research, or even personal assistance.

It's important to note that the methodology may vary depending on the specific goals, constraints, and resources available for developing a humanoid robot. Various research

institutions and companies employ different approaches and techniques to achieve their

4.0 CONCLUSION

In this dynamic and rapidly evolving field, the possibilities for humanoid robots are limited only by our imagination and technological advancements. As we navigate the complex terrain of robotics ethics, safety, and societal integration, it is essential to approach the development and deployment of humanoid robots with careful consideration and responsibility.

Humanoid robotics represents not only a testament to human ingenuity but also a testament to our enduring desire to push the boundaries of what is possible. As these robots continue to evolve, their potential to enhance our lives, drive economic growth, and transform industries is undeniable. The journey of humanoid robots is far from over, and the path ahead promises to be one of continued innovation, discovery, and collaboration.

5.0 APPLICATIONS

Humanoid robotics systems have a wide range of applications across various fields due to their versatile ability. Here are some notable applications of humanoid robotics systems:

I. Healthcare:

- **Assisting Patients:** Humanoid robots can assist patients with mobility issues by helping them stand up, walk, or transfer between beds and wheelchairs.
- **Rehabilitation:** They can aid in physical therapy by guiding patients through exercises and monitoring their progress.
- **Mental Health Support:** Some humanoid robots are designed to provide companionship and emotional support to patients, particularly those in long-term care facilities.

objectives.

II. Education:

- **Personalized Tutoring:** Humanoid robotics systems can serve as interactive tutors, providing personalized lessons and feedback to students.
- **Language Learning:** They can help individuals learn new languages through conversation and language exercises.
- **STEM Education:** In STEM (science, technology, engineering, mathematics) fields, humanoid robots can engage students in hands-on learning experiences and experiments.

III. Customer Service:

- **Front Desk and Concierge Services:** Humanoid robots can work as receptionists or concierges in hotels, offices, and other public spaces.
- **Information and Assistance:** They can provide information about products, services, and directions, improving customer service and reducing wait times.

IV. Entertainment:

- **Theme Parks:** Humanoid robots are used in theme park attractions, providing interactive and entertaining experiences for visitors.
- **Performing Arts:** They can perform in theatres, dance performances, and live shows, bringing characters to life with human-like movements and expressions.

V. Manufacturing and Industry:

- **Collaborative Manufacturing:** Humanoid robotics systems can collaborate with human workers on assembly lines, handling tasks that require dexterity and precision.
- **Quality**

Control: They can be used for quality inspection and testing of products in manufacturing environments.

- **Logistics:** They can also

be used in logistics to

transport goods and

materials. **VI. Research and**

Development:

- **Human-Robot Interaction Studies:**

Researchers use humanoid robotics systems as platforms to study human-robot interaction, cognitive science, and artificial intelligence.

- **Innovation:** Robotics researchers and engineers utilize humanoid robots to push the boundaries of robotics technology,

6.0 FUTURE SCOPES

The future scope of humanoid robots is vast and promising. They are expected to play a major role in many different industries and aspects of our lives.

I. **Companionship and caretaking:**

Humanoid robots can be used as companions for the elderly and disabled, providing them with companionship and assistance with daily tasks. They can also be used as nurses and doctors, performing routine tasks and providing emotional support.

II. **Training assistant:** Humanoid robots can

References:

1. Ambrose RO, Savely RT, Goza SM, Strawser P, Diftler MA, Spain I, and Radford N (2004). Mobile manipulation using NASA's robonaut. In the IEEE International Conference on Robotics and

leading to advancements in the field.

VII. Search and Rescue:

Disaster Response: Humanoid robots can navigate through disaster-stricken areas, assess damage, locate survivors, and provide support when human access is limited or unsafe.

VIII. Retail and Hospitality:

Inventory Management: In retail, humanoid robotics systems can assist with inventory management by scanning shelves for stock levels and discrepancies.

Room Service: In hotels, they can deliver items to guest rooms, improving efficiency and convenience.

be used as teaching assistants, providing instruction in military and industrial training, simulating real-world scenarios.

III. **Hazardous environments:** Humanoid robots can be used in hazardous environments, such as nuclear power plants and oil rigs, where it is too dangerous for humans to work. They can also be used in search and rescue operations.

IV. **Space exploration:** Humanoid robots can be used to explore space, where they can perform tasks that are too dangerous or difficult for humans. They can also be used to build and maintain space stations.

Automation (ICRA '04), IEEE, New Orleans, USA, 2: 2104-2109. <https://doi.org/10.1109/ROBOT.2004.1308134>

2. Asfour T, Regenstein K, Azad P, Schroder J, Bierbaum A, Vahrenkamp N, and Dillmann R (2006). ARMAR-III: An integrated humanoid platform for

- sensory-motor control. In the 6th IEEE-RAS International Conference on Humanoid Robots, IEEE: 169-175. <https://doi.org/10.1109/ICHR.2006.321380>
3. Behnke S (2008). Humanoid robots-from fiction to reality?. In the *Künstliche Intelligenz Heft*, 4, 5–9. Available online at: https://www.ais.unibonn.de/papers/KI08_Behnke.pdf
 4. Bluethmann W, Ambrose R, Diftler M, Askew S, Huber E, Goza M, and Magruder D (2003). Robonaut: A robot designed to work with humans in space. *Autonomous Robots*, 14(2): 179-197.
 5. Butterfass J, Grebenstein M, Liu H, and Hirzinger G (2001). DLR-Hand II: Next generation of a dextrous robot hand. In the *IEEE International Conference on Robotics and Automation (ICRA)*, IEEE, Seoul, South Korea, 1: 109-114. <https://doi.org/10.1109/ROBOT.2001.932538>
 6. Calinon S and Billard A (2007). Incremental learning of gestures by imitation in a humanoid robot. In the *2nd ACM/IEEE International Conference on Human-Robot Interaction (HRI)*, IEEE: 255-262. <https://doi.org/10.1145/1228716.1228751>
 7. Chestnutt J, Michel P, Kuffner J, and Kanade T (2007). Locomotion among dynamic obstacles for the Honda Asimo. In the *IEEE/RSJ International Conference on Intelligent Robots and Systems (IROS)*, IEEE, 2572-2573. <https://doi.org/10.1109/IROS.2007.4399431>
 9. Chua PY, Caldwell DG, Bezdicek M, Gray JO, and Davis S (2006). Tele-operated high speed anthropomorphic dextrous hands with object shape and texture identification. In the *IEEE/RSJ International Conference on Intelligent Robots and Systems*, IEEE, Beijing, China: 4018-4023. <https://doi.org/10.1109/IROS.2006.281861>
 10. Collins S, Ruina A, Tedrake R, and Wisse M (2005). Efficient bipedal robots based on passive-dynamic walkers. *Science*, 307(5712): 1082-1085.
 11. Cypher A and Halbert DC (1993). *Watch what I do: programming by demonstration*, MIT press, Cambridge, UK.
 12. Dahiya RS, Valle M, and Metta G (2008). System approach: A paradigm for robotic tactile sensing. In the *10th IEEE International Workshop on Advanced Motion Control (AMC '08)*, IEEE:



Development of IoT Based Monitoring System in Smart Agriculture

Jinnat Saba¹, Shams Tanveer^{1*}, Soumyata Singh¹, Sanghamitra Layek¹, Bikas Mondal²

¹Department of Electronics and Instrumentation Engineering, Narula Institute of Technology, Agarpara-700109, India

²Department of Electronics & Computer Science, Narula Institute of Technology, Agarpara - 700109, India

Correspondence*: tk23092012@gmail.com

Abstract:

Application of sensors in food and agriculture sectors improves environmental sustainability and a bright future in addition to feeding the world's population. This emerged as a transformative way, revolutionizing traditional practices and paving the way for greater efficiency, sustainability, and food safety. This abstract provides a concise overview of the multiuse applications of sensors in the agriculture sector. Sensors play a pivotal role in precision farming. Soil sensors enable real-time monitoring of moisture levels, humidity, nutrient content, and temperature, facilitating optimized irrigation and fertilization. Weather sensors provide accurate meteorological data, assisting farmers in making informed decisions regarding planting, harvesting, and resource allocation. Temperature and humidity sensors ensure the integrity of perishable goods during transportation and storage, reducing food waste. PH sensors provides the acidic or basic nature of the soil. Internet of Things (IoT) has enabled the creation of interconnected sensor networks which helps the farmer by providing the accurate data of the field which is beneficial as well as makes them understand the condition of field in a better way and also reduces some work load. In conclusion, sensor applications in the food and agriculture industry are pivotal in addressing the growing global challenges of food security, resource management, and environmental sustainability. As technology continues to advance, the integration of sensors and data-driven solutions promises to

revolutionize these industries, ensuring a more resilient and sustainable future for agriculture and food production.

Index Term: Temperature sensor, Humidity and Moisture Sensor, PH sensor, IoT, Stability Revolution.

Introduction:

A sensor is a device or component that notices physical changes or environmental conditions and reacts to them. These changes are transformed into electrical or digital signals that can be analyzed, displayed, or applied in a variety of ways. Sensors can be used to measure a variety of variables, including temperature, pressure, light, humidity, motion, and many others. In order to increase production efficiency, product quality, and sustainability, Different sensors can be used in the food and agriculture sector. The authors offer real-time data and monitoring capabilities. By the help of these sensors, we can access food quality monitoring, food traceability, Pesticide and Chemical residue detection, Nutritional analysis, Precision agriculture, Reducing the food waste, Allergen detection, Water quality monitoring, Livestock health monitoring and Supply chain transparency, thus ensuring that consumers have access to healthier food options [1]-[3]. The application of sensors in the food and agriculture industry can help prevent non- communicable diseases (NCDs) by improving food safety, quality, and traceability, thus ensuring that consumers have access to healthier food options [4]-[5]. Here is how sensors can contribute to NCD prevention in these industries:

1. Food Quality Monitoring:

Temperature and Humidity Sensors: These sensors can keep an eye on the conditions of perishable food storage and transit to make sure they are kept at the proper temperatures to avoid contamination and deterioration.

2. Food Traceability:

RFID (Radio-Frequency Identification) and QR Code Scanners: These sensors and technology can educate consumers about the source, preparation, and nutritional value of food products. This openness enables customers to make wiser, healthier decisions.

3. Pesticide and Chemical Residue Detection:

Chemical Sensors: These Sensors can find chemical pollutants and pesticide residues in food products, protecting customers from harmful substances. This can lower the chance of NCDs brought on by chemical exposure.

4. Nutritional Analysis:

Spectroscopy Sensors: These sensors are capable of analyzing the vitamins, minerals, and macronutrients that are present in food products. Customers can utilize this knowledge to choose a diet that is better for them.

5. Precision Agriculture:

Soil and Environmental Sensors: These sensors can keep an eye on the environment and the health of the soil, allowing farmers to maximize crop yield. They support healthy diets by making sure nutrient-rich foods are available [6].

6. Reducing Food Waste:

IoT Sensors: Food waste can be decreased with the use of these sensors that monitor food freshness and shelf life. Food waste reduction improves consumer access to nutrient-dense products and may result in lower prices [7].

7. Allergen Detection:

Allergen Sensors: For people who have food allergies, the ability of these sensors to detect allergens in food products is essential. Allergy reactions, which might be fatal, must be avoided in order to be prevented.

8. Water Quality Monitoring:

Water Sensors: Assuring the quality of the water used for food processing and irrigation helps stop contamination and the spread of waterborne infections, which indirectly aids in the reduction of NCDs [8].

9. Livestock Health Monitoring:

Animal Health Sensors: Sensors can keep an eye on the health and happiness of livestock, lowering the risk of zoonotic infections and ensuring the security of products obtained from animals.

10. Supply Chain Transparency:

Blockchain Technology:

Blockchain and sensors work together to build transparent supply chains that let customers follow their food from farm to table. This openness can encourage healthier

choices and foster consumer confidence in the food supply. Sensors in the food and agriculture sector can improve food quality, safety, and transparency, thereby enhancing consumer decision-making, lowering exposure to harmful substances, and ultimately assisting in the prevention of NCDs through healthier diets and lifestyles [9].

Table-1: Sensors and their function

Sensors	Functions
Optical Sensors	Optical sensors assess crop health, monitor soil properties, detect ripeness, and identify pests and sustainable farming practices.
Electrochemical Sensors	Electrochemical sensors analyze soil and water properties, optimizing fertilizer use and enhancing crop growth through precise data.
Mechanical Soil Sensors	Mechanical soil sensors measure soil compaction, aiding farmers in soil health assessment and crop root development.
Dielectric Soil moisture sensors	Dielectric soil moisture sensors measure soil moisture content for efficient irrigation and crop health monitoring in agriculture, aiding water resource management.
Location Sensors in Agriculture	Location sensors in agriculture use GPS or GNSS for precise tracking of equipment and assets, optimizing field operations and enabling data-driven decisions.
Electronic Sensors	Electronic sensors in agriculture collect data on various parameters such as soil moisture and temperature, supporting precision farming practices.
Airflow Sensors	Agricultural airflow sensors keep an eye on ventilation in barns and livestock facilities to ensure that crops and animals are kept in good health.
Insect and Pest monitoring sensors	These sensors can detect the presence of pest and insects in fields, allowing for timely pest control measures.
Light Sensors	Light sensors measure light intensity for crop growth assessment, helping optimize planting and harvesting times in controlled environments.
Temperature Sensors	Temperature sensors monitor air and soil temperatures to guide planting and harvesting decisions.
Livestock Monitoring Sensors	Livestock monitoring sensors such as RFID tags uses for tracking and health monitoring

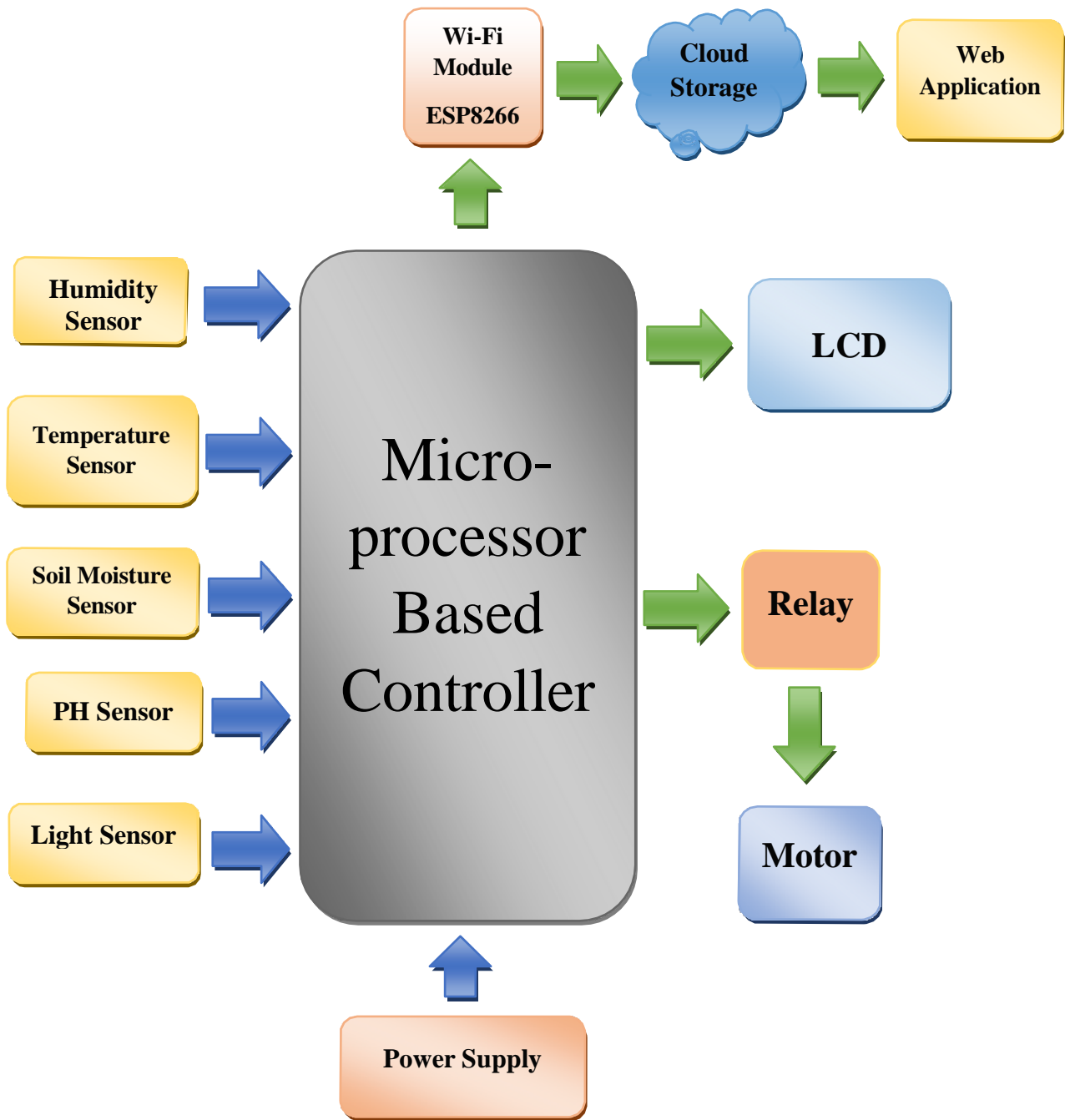

Figure 1: Block diagram of proposed of IoT Based Monitoring System in Smart Agriculture

Table-2: Sensors with their working range

Sensors	Quantity	Range
Humidity Sensor (DHT11)	1	0% RH~100% RH
Temperature Sensor LM35	1	-40°C~+80°C
Soil Moisture Sensor (LM393 Module)	1	ADC value 0-1023
PH Sensor	1	0-14 (9)
Light sensor	1	430 to 610 nm.
ESP 8266	1	Less than 20meter
Relay module	1	5V

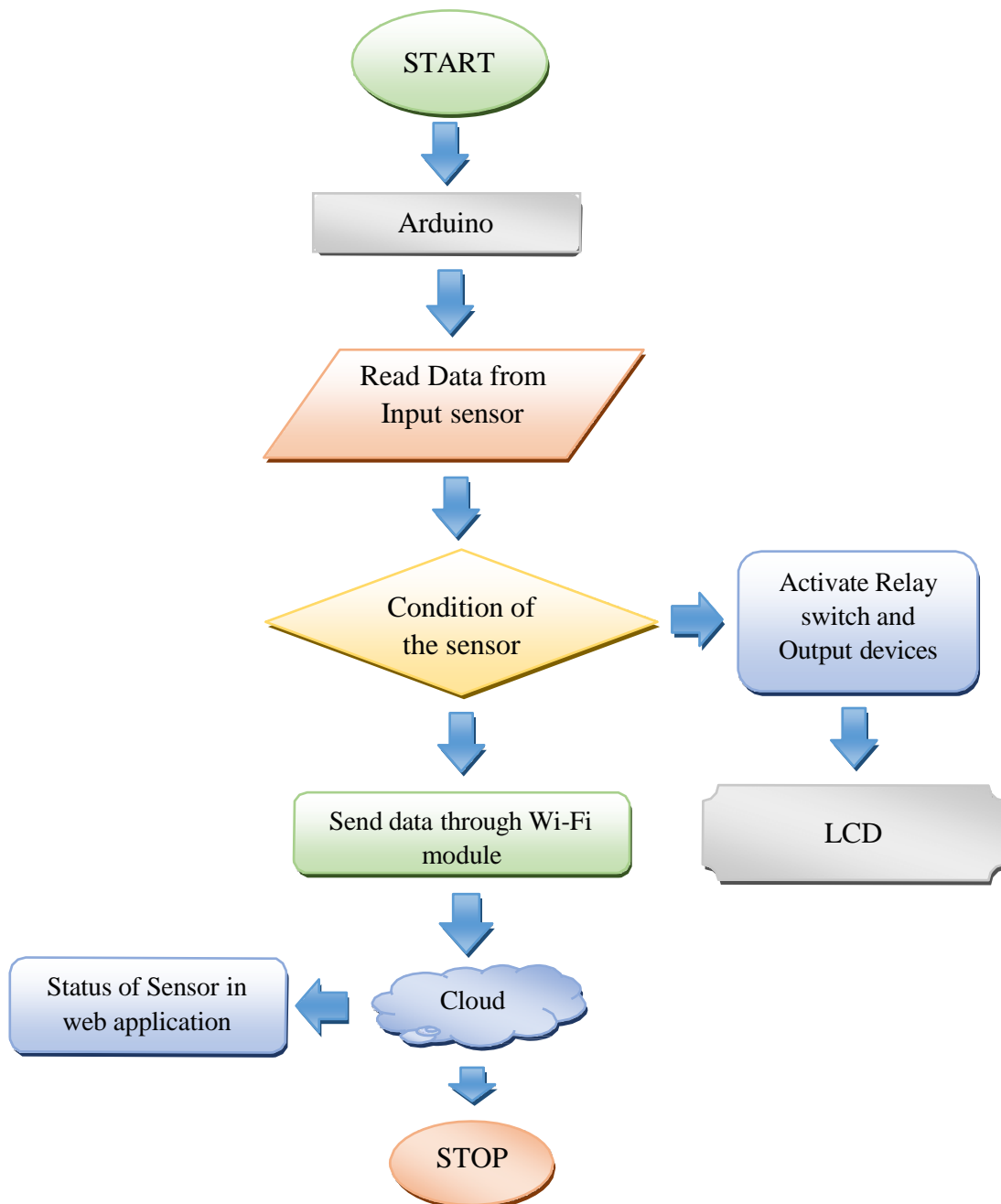

Figure 2: Flow Chart of Proposed IoT based Monitoring System in Smart Agriculture

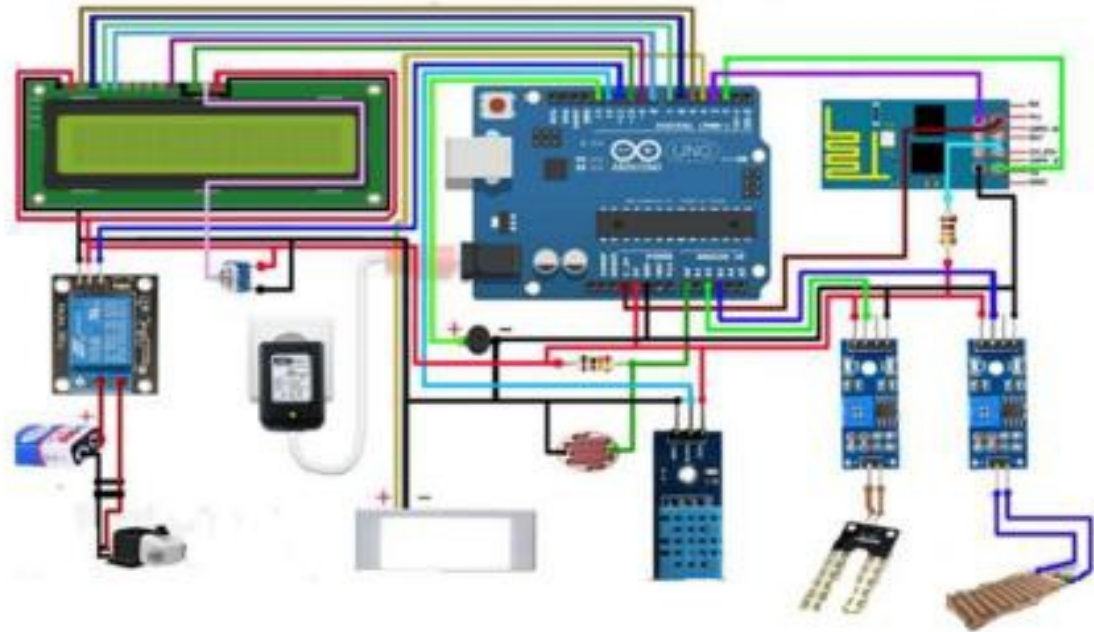

Figure 3: Circuit Diagram of Proposed System

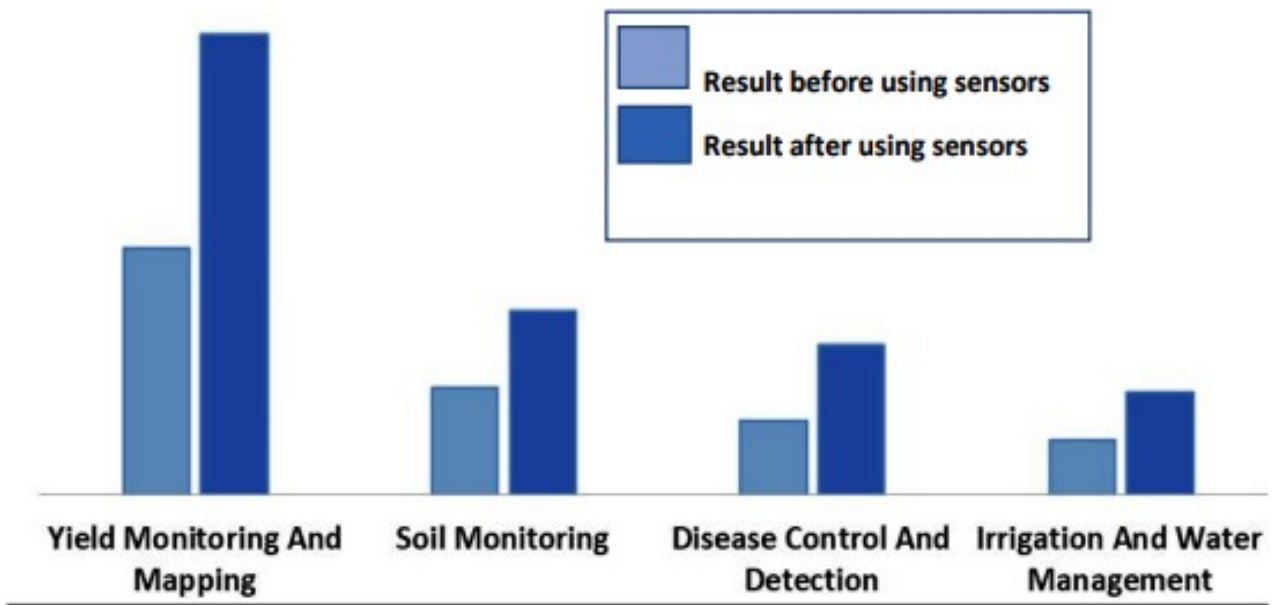

Figure 4: Graph showing result before and after using sensor

Results:

Whenever the moisture level is less than 40% the motor will turn on and supply the water to field and if the moisture level is greater than 40% the motor will automatically turn off. At night the light

sensor detects the darkness and turn on the lights at the field. Details of the crops (moisture level, temperature and humidity, rain, lights etc.) will display on LCD Board [10].

Conclusion:

As we know that agriculture plays a major role in our society. This paper mainly focusses on smart farming system. In future, while the people demand the comfort life, it is expected that this project will decrease the manual labor as it is fully automatic. Not only that but it will also provide farmers to use just the right amount of water and fertilizer. Also, we will get the best result in terms of not eating too much contaminated crops yield by farmer before of using sensor. Application of these sensors are as follows- agriculture livestock watering, crop irrigation, home gardens, for roof gardening irrigation system, soil moisture tracking, remotely tracking of the status of crops, can be used in smart greenhouse system, monitor climate conditions [11]. As well as it has many advantages which leads to energy efficient, decreases water wastage, eco-friendly, reduces manual labour, allows farmers to maximize yields using minimum resources such as water, fertilizers, seeds and etc., cost effective method, delivers high quality crop production.

References:

1. S. R. Prathibha, Anupama Hongal, M. P. Jyothi, "IOT Based Monitoring System in Smart Agriculture", IEEE Conf, International Conference on Recent Advances in Electronics and Communication Technology (ICRAECT), 2017.
2. R. Mythili, Meenakshi Kumari, Apoorv Tripathi, Neha Pal, "IoT Based Smart Farm Monitoring System", International Journal of Recent Technology and Engineering (IJRTE), ISSN: 2277- 3878, Volume-8 Issue-4, November 2019.
3. P. Prema, B. Sivasankari, M. Kalpana, R. Vasanthi, "Smart Agriculture Monitoring System using IoT," Ind. J. Pure App. Biosci. 7(4), pp. 160-165, 2019.
4. Harika Pendyala, Ganesh Kumar Rodda, Anooja Mamidi, Madhavi Vangala, Sathyam Bonala, Keerti Kumar Korlapati, "IoT Based Smart Agriculture Monitoring System", International Journal of Scientific Engineering and Research (IJSER), Vol 9, Issue 7, pp. 31-34, July 2021.
5. Swaraj C M, K M Sowmyashree, "IoT based Smart Agriculture Monitoring and Irrigation System," International Journal of Engineering Research & Technology (IJERT), vol. 8, issue 14, 2020.
6. Sushant S. Patil, "Internet-of-Things (IoT) Based Smart Agriculture," International Journal of Engineering Science and Computing, Vol 10, Issue. 5, 2020.
7. Niharika Agrahara, Amit Kushwaha, Saayali Vispute, Arshad Ubare, Siuli Das, "Aadhunik Krishi – IoT based Smart Farming", International Journal of Engineering Research & Technology (IJERT), Volume 09, Issue 03, February 2020.
8. Maheswari.D, Godhandaraman.B, Abinaya.M, Aswini.C, "Smart farming based on IoT monitoring system", International Journal of Innovative Research in Electrical, Electronics, Instrumentation and Control Engineering, Vol. 9, Issue 3, March 2021.
9. Navya B S, "IoT in Agriculture," International Journal of Advanced Research in Science, Communication and Technology (IJARSCT), Volume 6, Issue 1, June 2021.
10. V. Suma, "Internet of Things (IoT) based Smart Agriculture in India: An Overview," Journal of IoT in Social, Mobile, Analytics, and Cloud, Vol.03 (1), pp. 1-15, 2021.
11. Abhilash Lad, Sumitra Nandre, Krishna Raichurkar, Sumit Zarkhande, Priya Charles, "A Literature Survey on Smart Agriculture Monitoring and

Control System Using IOT”,
International Journal for Research in
Applied Science & Engineering
Technology, ISSN: 2321- 9653,
February 2022.



SMART HELMET FOR ALCOHOL DETECTION

Apurba Basumallick¹, Akash Bhattacharyya¹, Somshubhra Bose¹, Anirban Saha¹

Sanghamitra Layek²

Department of Electronics and Instrumentation Engineering

Narula Institute of Technology

81, Nilgunj Road, Agarpara, Kolkata-700109

Corresponding author's email: basumallickapurba05@gmail.com

ABSTRACT: In recent times, there has been a significant rise in the worldwide focus on road safety, and a notable part of accidents and deaths can be linked to drunk driving. By developing an intelligent helmet that incorporates an alcohol-detecting sensor, it becomes possible to identify drunk drivers in real-time. This paper introduces an innovative method for improving road safety. The proposed smart helmet utilizes advanced alcohol detection technology to analyze the driver's breath and detect the presence of alcohol molecules when they exhale. These non-invasive and non-intrusive sensors are made to deliver precise measurements of the blood alcohol content quickly, allowing for the prompt identification of potentially drunk drivers.

a significant impact is in enhancing safety of our roadways among the most pressing concerns in road safety is alcohol impairing a leading cause of accidents and fatalities worldwide to combat this problem we introduce the concept of a smart helmet with alcohol detection a groundbreaking innovation designed to detect alcohol intoxication advisers and contribute to a safer and more responsible driving environment.

A proactive and cutting-edge technological solution to this specific problem is the Smart Helmet with Alcohol Detection. By incorporating state-of-the-art alcohol sensing technology into a driver's helmet, this ground-breaking gadget continuously checks the person's rate for the presence

KEYWORDS: road safety, alcohol impair driving, alcohol detecting sensor, alcohol concentration.

1.0. INTRODUCTION:

The advent of technology has continuously reshaped the way we address various challenges and one area where it has made

of alcohol molecules. When alcohol intoxication is detected, it operates in real time and provides rapid input to the wearer as well as other parties like law police or designated contacts.

This paper attempts to improve road safety while simultaneously increasing public awareness of the risks associated with drunk driving. The Smart Helmet is a powerful tool for preventing accidents and saving lives, and it seeks to supplement ongoing efforts to combat drunk driving by combining conventional methods with a cutting-edge strategy that makes use of contemporary technology. The Smart Helmet embodies the principle of responsible drinking and responsible driving.

We'll go deeper into the technical details, design considerations, and potential advantages of the Smart Helmet with Alcohol Detection in the parts that follow, illuminating how this innovation might help create a safer, more accountable, and responsible driving culture in our communities.

2.1. MOTIVATION BEHIND THE PAPER:

The initiative for alcohol-detection smart cars was originally inspired by the need to combat the fatal and pervasive issue of drunk driving. The creation of such a gadget is driven by a number of major motives:

- **Public safety:** Worldwide, drunk driving contributes significantly to traffic accidents, injuries, and fatalities. These mishaps cause

incalculable human misery and financial losses. This paper, which is driven by a dedication to public safety, seeks to lessen the number of accidents caused by alcohol and save lives.

- **Preventative Approach:** Traditional techniques used by law enforcement to identify drunk drivers, such as field sobriety tests and Breathalyzer testing, are reactive in nature. An alcohol-detection feature on a smart helmet adopts a proactive approach by seeing drunk drivers before they even get behind the wheel, so preventing accidents from happening in the first place.
- **Immediate Feedback:** When alcohol intoxication is detected, the Smart Helmet immediately notifies any nearby external authorities. This quick reaction enables prompt intervention and may discourage people from trying to drive while intoxicated.
- **Technological Advancements:** The goal in developing preventable equipment like smart helmets that can accurately detect alcohol intoxication is to use technological breakthroughs for the benefit of society as a whole. Advances in sensor technology, data processing, and communication systems have made it possible.
- **Compliance with legal limits:** There are stringent legal restrictions on driving while intoxicated in several nations. The smart helmet can assist people in adhering to these limitations and avoiding the negative legal repercussions of going over them.

3.1. COMPONENTS LIST:

1. Helmet
2. Power Supply
3. Arduino Uno
4. MQ-3 Alcohol Sensor
5. Transmitter and Receiver Module
6. Buzzer
7. Switch
8. Connecting Wires
9. LED light
10. 5V Relay
11. BC547 Transistor

the bike unit using the transmitter.

4.3. Block diagram of bike unit:

4.1. METHODOLOGY:

4.2. Block diagram of helmet unit:

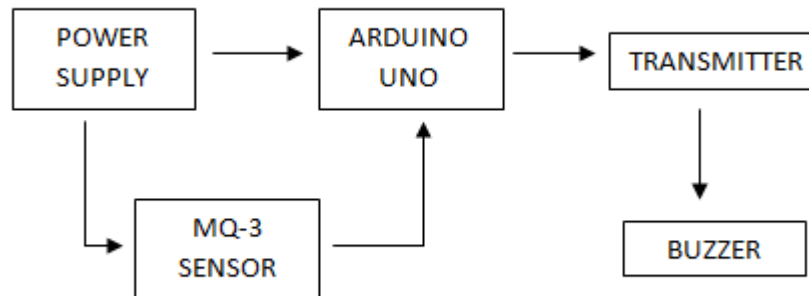

Figure: 01 Working Process in helmet unit

Here, we have used arduino uno as the microcontroller of this device. The arduino uno receives the inputs from MQ-3 sensor which is used for alcohol detection from a person's breath. This device will provide the data of amount of alcohol molecules to arduino uno. Those signals are analyzed inside the microcontroller by a custom written algorithm whenever either signal identifies a danger situation the controller will inform the writer with the alarm and send a lockdown command to

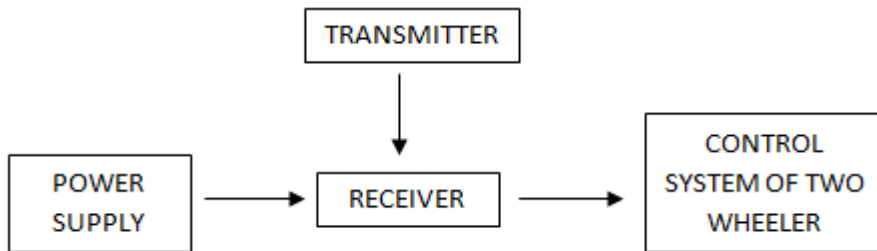

Figure: 02 Working Process in bike unit

According to this block diagram, whenever the controller unit receives a lockdown command to the receiver it will check whether the bike is running or not. If the bike is not running the controller unit will cut off the power to the ignition unit. If the bike is running a high frequency alarm will be fired to indicate the danger to the

rider. There were products to detect alcoholic bike riders but the uniqueness of this product is this it can detect both alcohol individually and lockdown or raise the alarm according to the situation this is specifically designed for bike riders.

5.0. CIRCUIT ANALYSIS:

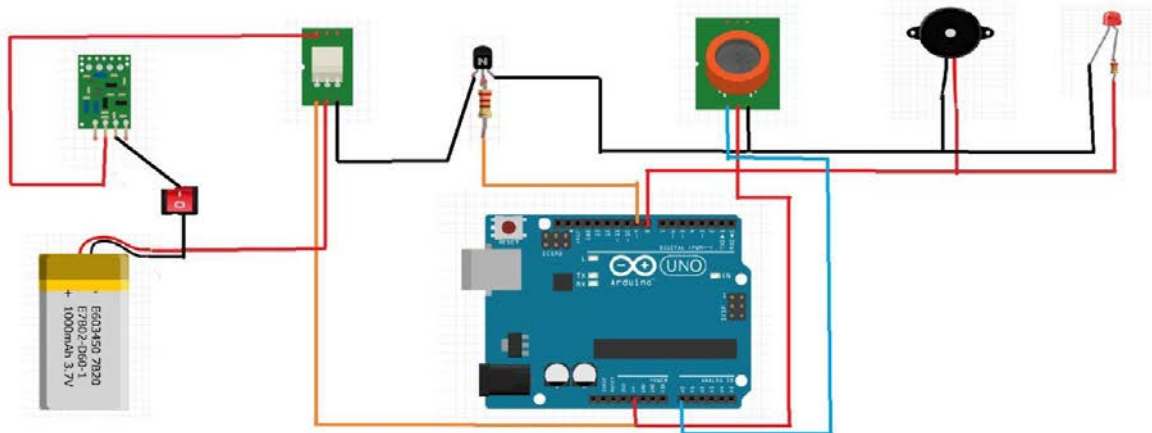

Figure: 03 Circuit analysis in helmet unit

This is the circuit analysis of the connections that we have implemented in the helmet section. Based on this connection, the first step of our smart helmet starts functioning.

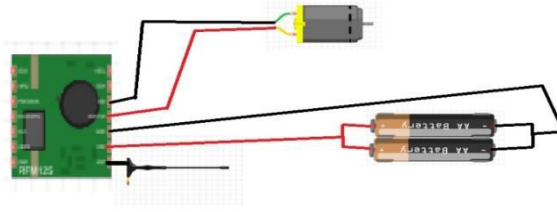

Figure: 04 Circuit analysis in bike unit

This is the circuit analysis of the connections that we have implemented in the bike's control section. Based on this connection, the second step of our smart helmet starts functioning leading to the complete safety of the driver.

6.0. CONCLUSION:

The safety of the bike riders can be increased using this helmet by getting some of the major causes of accidents such as alcohol consumption. Above mention situations will identify by the system and will inform the driver by an alarm at the same time the ignition system will not function if the rider has not started the bike yet. If the system detects either of those causes while the bike is moving the writer will receive the warning message using the high frequency alarm and he will be commanded to stop the bike immediately. With the success of this paper, we would like to develop much more advanced devices to provide help to our society. In the end, we would like to thank our mentor Mrs. Sanghamitra Layek Madam for her great contribution in our paper. Without her guidance and support, this paper wouldn't become a success.

7.1. REFERENCES:

1. A smart helmet with a built-in drowsiness and alcohol detection system, Journal of research technology and Engineering, Vol 1, Issue 3, July 2020
2. P. Prasad, R. Mohan, S. L. Raj, S. Sreelekshmi, D. R. Pillai, Smart Helmet and Intelligent Bike System, Technical Research Organisation India, Vol 5, Issue 5, pp. 29, 2018.
3. R. Prudhvi Raj, Krishna Kanth and K. Bhargav Aditya Bharath, "Smart-tec Helmet", Electrical and Electronics Engineering GITAM University Rushikonda Visakhapatnam India. Advance in Electronic and Electric Engineering, vol. 4, pp. 493-498, 2014.

4. Vivien Melcher et al., "Smart vital signs and accident monitoring system for motorcyclists embedded in helmets and garments for advanced eCall emergency assistance and health analysis monitoring", *Procedia Manufacturing*, vol. 3, pp. 3208-3213, 2015.
5. M. Muthiah and R. K. Sathiendran, "Smart helmets for automatic control of headlamps", 2015 International Conference on Smart Sensors and Systems (IC-SSS), 2015.



DESIGN APPROACH OF A GESTURE AND EMG(ELECTROMYOGRAPHY) CONTROLLED BIONIC ARM

Sparsho Chakraborty¹

Sayantana Maitra¹

Md. Avaish Siddiqui¹

Diksha Jha¹

Susmita Das^{2*}

Department of Electronics and Instrumentation Engineering, Narula Institute of Technology, Agarpara-700109,
Kolkata, India

Correspondence*: susmitad2k17@gmail.com

Abstract

One of the major societal issues that hasn't been fully addressed is the existence of high-precision work in the industrial and medical sectors. Furthermore, because a human hand trembles, high-precision surgery is necessary in the medical industry in particular. These normal hand tremors might have disastrous effects if they happen in the middle of surgery. We suggest a robotic arm with a 9-axis gyro sensor (mpu6050), a flex sensor, and an Electromyograph (EMG) sensor to solve this issue. Every 25 milliseconds, an Arduino program simply maps the analog inputs while reading the array step-by-step and moving the robotic arm. In order to synchronize the starting and ending locations of the arm, a programmed loop calculates various micro-steps for each servo motor to fix the motions. The robotic arm travels slower for shorter lengths and faster for larger lengths. The robotic arm is then managed by the arm movement, and the image sensor manages the claw. Flex sensors are also employed, and they are further mapped to move certain servos, enabling more precise operations. This allows us to pick up things and deposit them at the designated spot using the robotic arm. The suggested device's ability to accurately duplicate the same set of actions the user coded precisely and more quickly makes it helpful for the healthcare sector. This robotic device can carry loads in the mining and construction sectors if its dimensions are increased.

Keywords: MPU6050, Electromyograph (EMG), Robotic arm, Flex Sensor, Arduino

1. Introduction

The term "servo robots" is derived from servo motors [6], which transform rotational energy into linear energy. Servo motors do not rotate freely and constantly as our standard DC motors do. The DC motor rotates constantly, whereas this one has a maximum rotational speed of 1800. The capacity to replicate actions and remember them for future use is a feature of our servo robot. Through the Arduino Nano's embedded MCU (Microcontroller Unit), the actions may be modified and programmed further. It powers the Arduino and the servo motors using a 220-volt AC to DC rectifier circuit and a voltage regulator for 5-volt input. This robot's task is to lift things and deposit them in containers using a wireless manner of action.

1.1. History

George C. Devol, a Louisville, Kentucky-based inventor, built the first robots as we know them in the early 1950s. He created and received a patent for a manipulator that can be reprogrammed, known as "Unimate" from "Universal Automation". He made several unsuccessful attempts to market his product over the following ten years.

1.2. S.C.A.R.A (Selective Compliance Articulated Robot Arm)

The SCARA type provides the foundation for our robotic arm. One kind of industrial robot is SCARA. Selective Compliance Assembly Robot Arm or Selective Compliance Articulated Robot Arm is what the abbreviation means [3]. Selective compliance refers to the arm's minor flexibility in the X-Y direction but stiffness in the Z direction according to the parallel-axis SCARA joint configuration. This is helpful for many different assembly tasks, such as inserting a round pin without binding in a round hole. The second feature of SCARA is its two-link arm configuration, which is articulated and resembles human arms. Due to this characteristic, the boom may extend into constrained spaces before retracting or "folding" out of the way. This makes it easy to load or unload closed process stations or move parts from one cell to another.

In general, SCARAs outperform equivalent Cartesian robotic systems in speed. Their straightforward and undisturbed installation on a single pedestal has a modest environmental impact. However, SCARAs may cost more than equivalent Cartesian systems, and the control software requires inverse kinematics for motions that are interpolated linearly. But often this software is invisible to the end user and includes SCARA.

In 1981, Sankyo Seiki, Pentel, and NEC unveiled the SCARA robot, a brand-new idea in the field of assembly robotics. Hiroshi Makino, a professor at the University of Yamanashi, provided direction for the robot's development. He could fit the holes in the XY-axes since his arm was flexible in the XY- axes but hard in the Z-axis.

2. Methodology

SYSTEM REQUIREMENTS

1. Arduino nano 5v/16Mhz,
2. 3*mega servo motor Mg996R (180 rotation),
3. 3*micro servo sg90
4. Rectifier circuit and voltage regulator (220vAC-5v DC),
5. Jumper cables,
6. Vero board
7. 3*Resistor(220ohm),
8. flex sensors*3
9. EMG sensor

2.1 Connection Diagram:

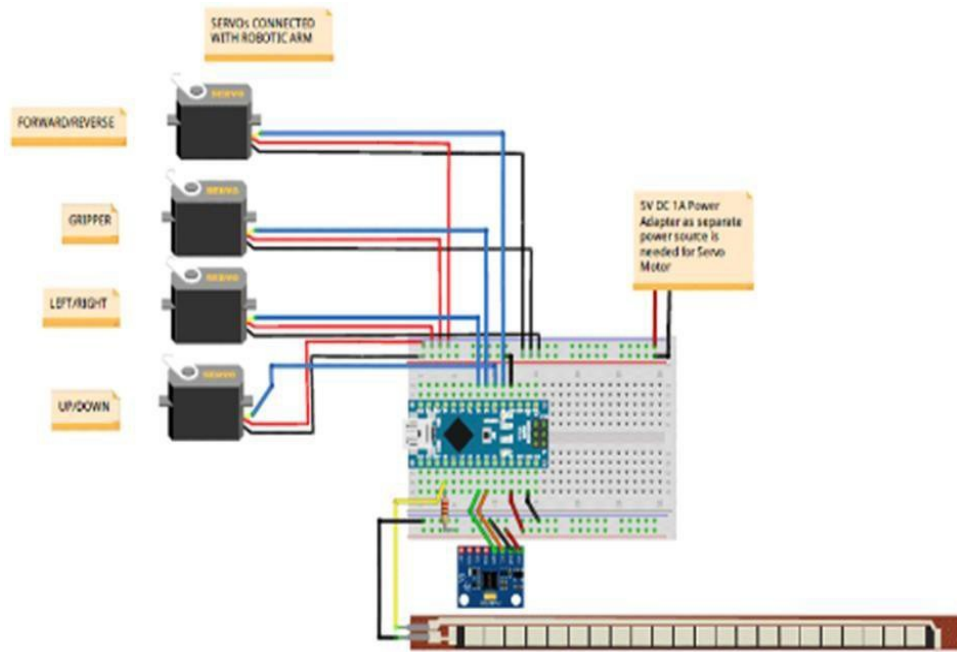

Fig.1: Connection Diagram

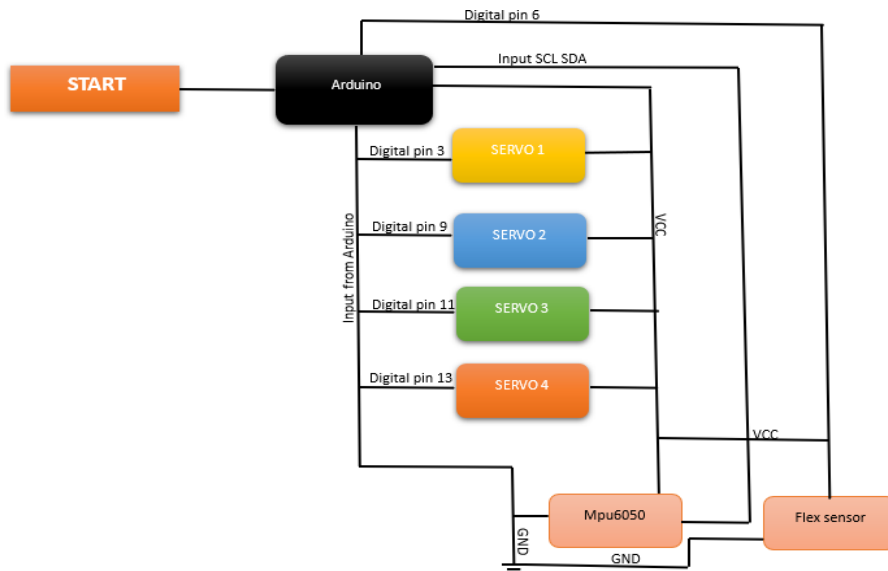

Fig 2: Working of the Robotic Arm

Result:

The 6-axis gyro sensor mpu6050 [4], the flex sensor, and the EMG sensor are the three most often utilized sensors on the robotic arm. The button on the circuit that duplicates the actions of the robotic arm must be double-pressed. The Arduino code then iteratively scans the array and moves the robotic arm every 25 ms while only transferring the analog inputs. A programmed loop calculates several micro-steps for each servo motor to synchronize the starting and ending locations of the arm in order to fix the motions. The robotic arm travels slower for

shorter lengths and faster for larger lengths. The arm then uses the inbuilt Arduino code to copy the action and display the motors' voltage and RPM on an LCD screen. The robotic arm is then controlled by the arm movement and the claw is controlled by the EMG sensor [1][2]. Furthermore, flex sensors are used [5], which are also further mapped to move specific servos, which can lead to more precision work. Through this, we can use the robotic arm to pick up objects and place them at the given point.

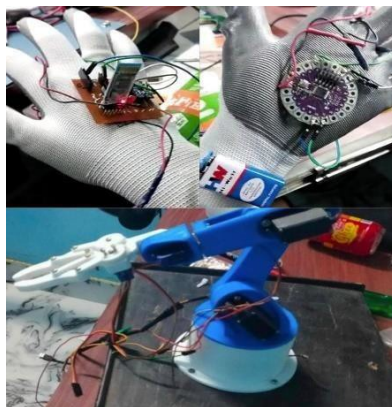

Fig. 3: Hardware Prototype

References:

1. Matsubara, T., Hyon, S. H., & Morimoto, J. (2011, September). User-adaptive myoelectric interface for EMG-based robotic hand control. *Neuroscience Research*, 71, e409. <https://doi.org/10.1016/j.neures.2011.07.1793>
2. Unanyan, N. N., & Belov, A. A. (2021, January 1). *Low-Price Prosthetic Hand Controlled by EMG Signals*. IFAC-PapersOnLine; Elsevier BV. <https://doi.org/10.1016/j.ifa.2021.10.463>
3. Mashhadany, Y. A. (2012, January 1). *SCARA Robot: Modeled, Simulated, and Virtual- Reality Verified*. Communications in Computer and Information Science. https://doi.org/10.1007/978-3-642-35197-6_10
4. Neto, P., Pires, J. N., & Moreira, A. P. (2009, September 1). *Accelerometer-based control of an industrial robotic arm*. <https://doi.org/10.1109/roman.2009.5326285>
5. Syed, A., Agasbal, Z. T. H., Melligeri, T., & Gudur, B. (2012, January 1). *Flex Sensor Based Robotic Arm Controller Using Micro Controller*. Journal of Software Engineering and Applications; Scientific Research

Publishing.

[https://doi.org/10.4236/jsea.2012.](https://doi.org/10.4236/jsea.2012.55042)

55042

6. Shulhan, S., Astwensa, F., Fauzan, F. R., & Bukhori, I. (2021, April 12). *Robotic Arm Using Servo Motor and Arduino Uno Controlled with Potentiometer*. Journal of Electrical and Electronics Engineering. <https://doi.org/10.33021/jeee.v3i2.1488>



Li-Fi Music Systems for Concerts

Aishani Sil¹, Souradeep Das¹, Arpita Das¹, Rimi Sengupta¹

¹Department of Electronics & Communication Engineering, Institute of Engineering & Management, University of Engineering & Management, Kolkata, University Area, Plot No. III – B/5, New Town, Action Area – III, Kolkata – 700160

Abstract:

As the wireless communication is growing each day, demand for Light Fidelity abbreviated as Li-Fi has increased that uses visible light, ultraviolet, and infrared spectrums in order to transmit data between devices. It is advantageous over many other communication systems due to its high-speed connectivity that can withstand higher data rates. Furthermore, its environmentally friendly nature and high security offerings make it even better. On the other hand, Li-Fi does not require any licensing from the government for its access, making it cost effective. Starting from the previous generation till the present, elderly as well as youths love to attend concerts. These are even made more harmonious when a good music system is installed. Here comes one of the usability of Li-Fi, where light can be used as a medium to transmit the audio signals from the stage to the amplifier connected speakers placed far away from the stage. This reduces the haphazard wire management making the setup more time and cost efficient. Other technologies like Bluetooth and Wi-Fi only support a range of ten meters where Li-Fi beats them by a huge margin. Additionally lossless and High-Resolution (Hi-Res) audio can be transmitted wirelessly due to its support to higher bandwidth and data rates. In this paper, a study on the Li-Fi technology is done and the same is implemented in an advanced music system for transferring audio data from one place to another using light signal.

Keywords: Li-Fi, Lossless audio, Bluetooth, Wi-Fi.

1. INTRODUCTION

Professor Harald Haas, of the University of Edinburgh, UK, is the father of Li-Fi technology. The term Visible Radiation Communication (VLC) puts forth the use of visible radiation of electromagnetic spectrum for data transmission [1]. Light Fidelity (Li-Fi), technology is developed by a research team at the University of Edinburgh. It is a current and present-day wireless communication technology that validates negligible transmission of data using electromagnetic waves, preferably light. Li-Fi has the potential to complement Wi-Fi due to the availability of broad bandwidth, non-existence of electromagnetic interference, high security, and high reliability [2,3,4]. Data may be obtained within the area of visible light by means of electronic gadgets with photodiode. In order to provide enhanced coverage, a hybrid Li-Fi and Wi-Fi network, which combines the high-speed data transmission of Li-Fi and the relatively large coverage of Wi-Fi, is envisioned for indoor wireless communications [5]. Wi-Fi plays an effective role in wireless data coverage within buildings, while Li-Fi will provide excellent data coverage in particular locations without any radio interference problems. An alternative to Wi-Fi for limited or short-lived wireless communication technology is Li-Fi communication. As the spectrum of Wi-Fi and Li-Fi is non-overlapping, therefore they would not

interfere with each other, as a result the hybrid network will provide higher system throughput as compared to an independent Li-Fi or Wi-Fi network [6]-[8]. From hybrid network point of view, there are two main problems which are required to be addressed for load balancing, namely, user association or access point (AP) selection and Resource allocation. In case of hybrid network [9],[10], the issue in AP selection is challenging firstly due to coverage area of Li-Fi and Wi-Fi network overlaps each other and secondly Wi-Fi covers larger area but have lower capacity, thus, is more prone to overload [11]-[15]. In any performance or festival, we can install or approve such wireless technology systems like Li-Fi for better throughput to avoid the desultory and erratic wire arrangement. This reduces havoc and costs and increases maintainability. This paper is based on installing Li-Fi technology in any concerts for better sound version and reducing the random wire management. The methodology along with the framework diagram and result is discussed in the following sections of

the paper.

2. METHODOLOGY

The idea behind our proposed work is to utilize Li-Fi technology in-order to transmit audio signal mostly in big speakers used in concerts placed at a distance more than ten meters from the stage. With the use of this the lights on the stage facing towards the audience can be used to transmit the audio signals from the stage to the speakers placed even more than ten meters away wirelessly. For our proposed work, the hardware components used are LED bulb, Auxiliary (AUX) cable, 270Ω resistor, photodetector (Solar panel), power supply, audio source (microphone or mp3 player) and audio output device (speakers connected to amplifier). The overall overview of the proposed architecture of the model is proposed in Figure 1. A comparison between Li-Fi and Bluetooth is discussed in Table 1.

Table 1: Comparison between Li-Fi and Bluetooth Technology.

Sl no.	Li-Fi	Bluetooth
1.	Uses light wave for data transmission.	Uses radio wave for data transmission.
2.	No specific operating frequency.	Operating frequency is around 2.4 GHz
3.	Data transfer rate are even higher than 1 Gbps.	Data transfer rate is around 800 Kbps.
4.	Due to higher data rate availability, support of Hi-Res lossless audio having bit rates about 24-bit/192kHz or 9216kbps audio streaming is possible.	Due to low data transfer rates, support of lossless audio streaming is not possible.
5.	No licensing is required for using this technology.	Licensing is required for using this technology.
6.	Highly secured.	Security is not up to Li-Fi's standard.
7.	Requires no software to operate it.	Requires software for its operation.
8.	Range is more than 10 m and can be even made better by improving the directivity and intensity of light.	The most common type class 2 Bluetooth can operate upto 10 m range.

3. Algorithm

The operating procedure of Li-Fi is easier than it sounds. The flickering of light that causes the light to switch ON and OFF thousands of times in a second causes production of digital

signal. The ON state transmits a digital signal 1 whereas OFF state transmits 0. A light emitting diode (LED) placed in the transmitter end acts as the transmitter and a photo detector (light sensing diode preferably solar panel) is placed at the receiver end that acts as a receiver. It is the photo detector, here

solar panel that senses binary 1 and 0 by the flickering of LED and delivers the data to the destination. With the use of this technology each and every LED source can be served as a data

transmission hub. The framework diagram of our proposed model is depicted in Figure 3 along with its experimental setup shown in Figure 2.

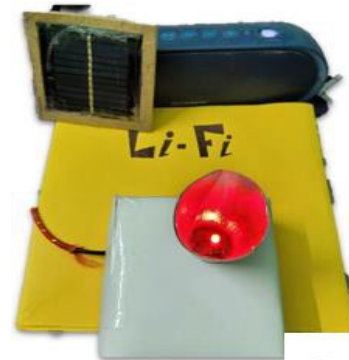
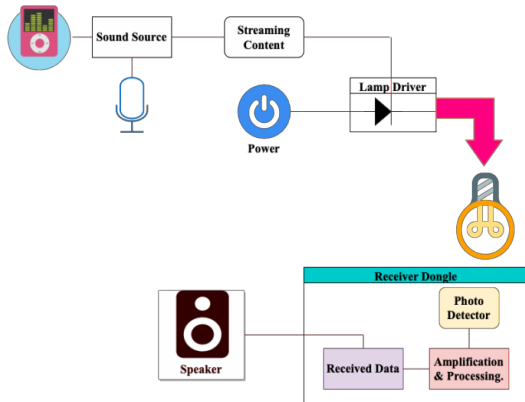

Figure 1: An overview of Li-Fi' architecture.

Figure 2: Experimental setup.

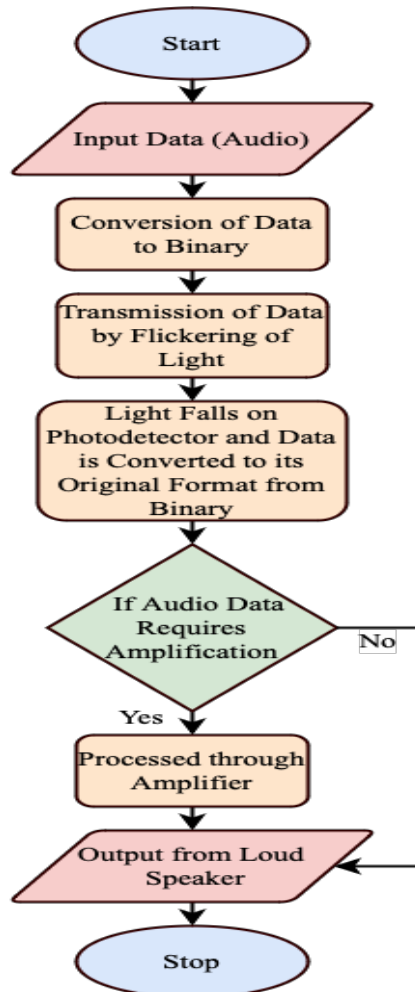

Figure 3: Framework diagram of our proposed model.

4. RESULTS

A Li-Fi based audio transmitting model was successful in transmitting audio signals without any loss from the audio source to the amplifier connected speaker wirelessly. The source (audio source) was kept at about ten meters far from the destination (speakers) and we observed that the latency was about 0.03 milliseconds for the signal to reach the destination which is far better than Bluetooth technology that takes about 34 milliseconds to 300 milliseconds to reach the destination. Furthermore, using this technology, we can transmit Hi-Res lossless audio having bit rates about 24-bit/192kHz or 9216kbps wirelessly, that was impossible using Bluetooth. The experimental setup is shown below in Figure 3.

lights in any theatre or auditorium can be used as Li-fi epicenters or hubs where the light can be used as a means to transmit the audio signals from a podium or a stage to the amplifier connecting the speakers placed far away from the podium or the stage. This reduces the irregular or disorganized wire management, making the setup more time-efficient and cost-effective. Use of light will not intermeddle with any electronic wiring and hence this technology is very much secured and unthreatening to the human lives.

Table 2: Study of effect of distance on latency for Li-Fi based system.

Distance between source and destination	Latency
10 m	0.0000333 ms
7 m	0.0000234 ms
5 m	0.0000167 ms
3 m	0.00001 ms

5. CONCLUSION

Li-fi is an apparently prominent technology that focuses on wide usage of wireless applications. It helps in greater area of coverage unlike a single Wi-Fi router. This technology provides high speed communication at gigabytes per second. One of the usability of Li-Fi is, any light source for example the halogen

REFERENCES

- [1] Haas, Harald. "Visible light communication." *2015 Optical Fiber Communications Conference and Exhibition (OFC)*. IEEE, 2015.
- [2] H. Haas, "Li-Fi: Conceptions, misconceptions and opportunities," in Proc. 2016 IEEE Photonics Conference (IPC), 2016.
- [3] R. Ahmad, A. Srivastava, and H. Al Selmy, "Advanced Modulation Techniques for Low PAPR in VLC System," in Proc. 20th International Conference on Transparent Optical Networks (ICTON), 2018.
- [4] Bhanse, Saily P., and Savita R. Pawar. "Li+ Wi Fi: The Future of Internet of Things." *2018 3rd International Conference on Communication and Electronics Systems (ICCES)*. IEEE, 2018.
- [5] Wu, Xiping, Majid Safari, and Harald Haas. "Access point selection for hybrid Li-Fi and Wi-Fi networks." *IEEE Transactions on Communications* 65.12 (2017): 5375-5385.
- [6] Shanmughasundaram, R., S. Prasanna Vadanam, and Vivek Dharmarajan. "Li-Fi based automatic traffic signal control for emergency vehicles." *2018 Second International Conference on Advances in Electronics, Computers and Communications (ICAEECC)*. IEEE, 2018.
- [7] Yunlu Wang et al., "Optimization of load balancing in hybrid Li-Fi/Wi-Fi networks," *IEEE Transactions on Communications*, vol. 65, no. 4, pp. 1708-1720, 2017.
- [8] Wentao Zhang et al., "Design and realization of indoor VLC-Wi-Fi hybrid network," *Journal of Communications and Information Networks*, vol. 2, no. 4, pp. 75-87, 2017.
- [9] Hassan, Rosilah, et al. "Visible light communication technology for data transmission using li-fi." *2020 2nd International Conference on Computer and Information Sciences (ICCIS)*. IEEE, 2020.
- [10] Selvi, S. Arunmozhi, R. S. Rajesh, and M. Angelina ThangaAjisha. "An efficient communication scheme for Wi- Li-Fi network framework." *2019 Third International conference on I-SMAC (IoT in Social, Mobile, Analytics and Cloud)(I-SMAC)*. IEEE, 2019.
- [11] Wang, Yunlu, and Harald Haas. "Dynamic load balancing with handover in hybrid Li-Fi and Wi-Fi networks." *Journal of Lightwave Technology* 33.22 (2015): 4671-4682.
- [12] Soni, Nidhi, Mayank Mohta, and Tanupriya Choudhury. "The looming visible light communication Li-Fi: An edge over Wi-Fi." *2016 international conference system modeling & advancement in research trends (SMART)*. IEEE, 2016.
- [13] Xiping Wu et al., "Two-stage access point selection for hybrid VLC and Wi-Fi networks," in Proc. 27th Annual International Symposium on Personal, Indoor, and Mobile Radio Communications (PIMRC), 2016.
- [14] Kulkarni, Shivaji, Amogh Darekar, and Pavan Joshi. "A survey on Li-Fi technology." *2016 International Conference on Wireless Communications, Signal Processing and Networking (WiSPNET)*. IEEE, 2016.
- [15] Ahmad, Rizwana, and Anand Srivastava. "Optimized user association for indoor hybrid Li-Fi Wi-Fi network." *2019 21st International Conference on Transparent Optical Networks (ICTON)*. IEEE, 2019.



American Journal of **Electronics & Communication**

Society for Makers, Artists, Researchers and Technologists,
USA 6408 Elizabeth Avenue SE, Auburn, Washington 98092.

ISSN 2690-2087